

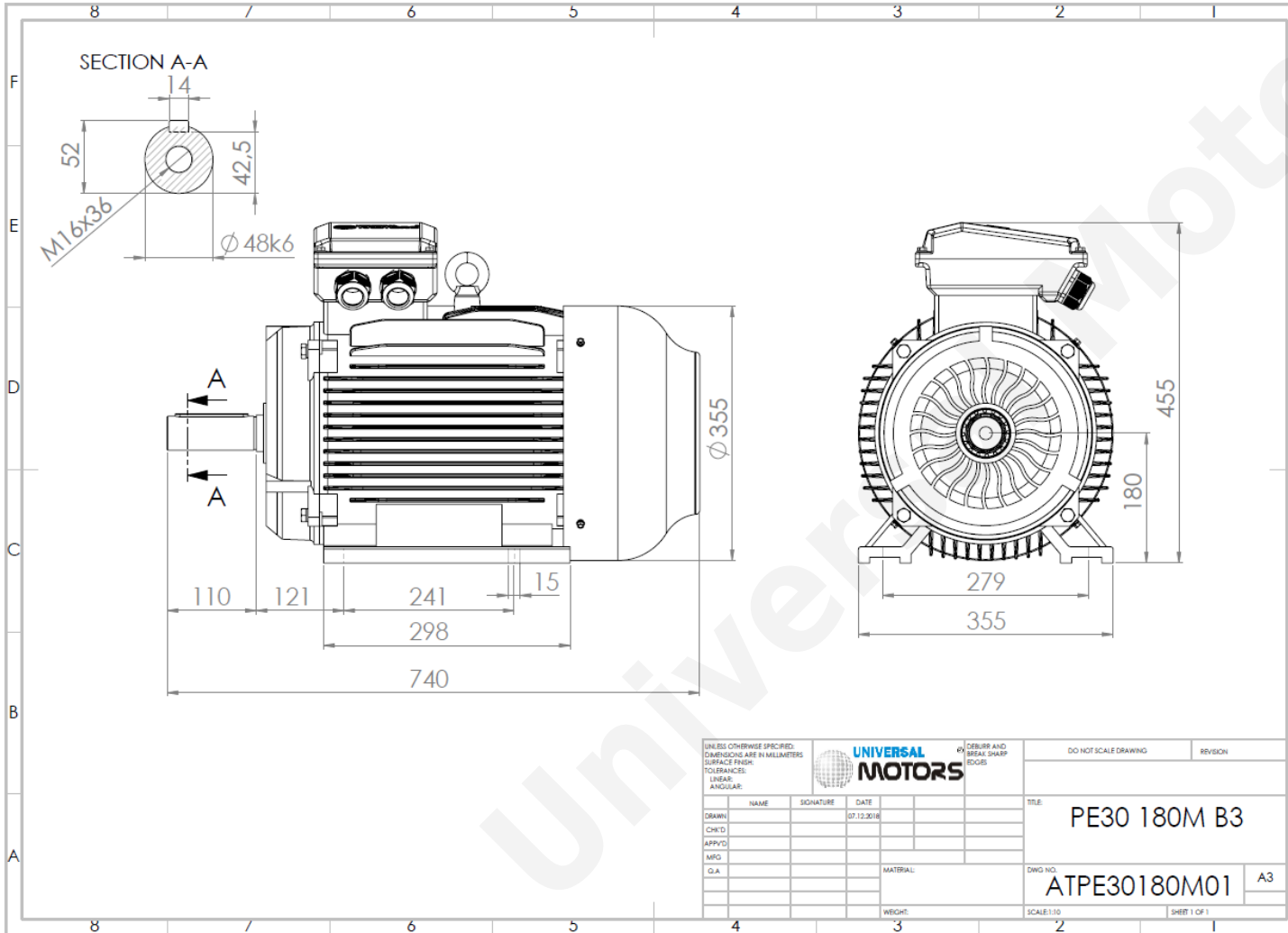

TECHNICAL DATA

Three Phase Electric Motors - Cast Iron Frame
 PE30 180 M 4 IE3
 18.5 kW / 25 Cv
 1475 RPM



Motor type:	PE30 180 M 4 IE3
Output:	18.5 kW / 25 Cv
Speed (min ⁻¹):	1475 RPM
Frequency:	50 Hz
Voltage:	400 V
Current:	32.5 A
Power factor (Cos Ø):	0.86
Poles:	4
Insulation class:	F
Temperature rise Class:	B
Efficiency 50%:	92.1 %
Efficiency 75%:	93.0 %
Efficiency 100%:	92.6 %
Torque:	120 N.m
Tstarting/Tnominal:	2.0
Istarting/Inominal:	7.8
Tmaximum/Tnominal:	2.3
Noise:	63 Db(A)
Weight:	196 Kg
Bearing DE:	6311 C3
Bearing NDE:	6311 C3

Regime - S1

Altitude - 1000m

Environment Temperature - 40°C

CONTACTS:

UNIVERSAL MOTORS Tel: +351 252 299 080
 Rua de São Brás, 745 Fax: +351 252 299 089
 4480-782 VILA DO CONDE Mail: geral@universalmotors.pt

* References applied only in the UK